

License: CERN-OHL-S 2.0

Engineer: Lukas F. Hartmann

<https://mntre.com>

MNT Research GmbH

Sheet: /Reform 2 Audio/

File: reform2-audio.sch

Title: Reform 2 Audio

Size: A4

Date: 2020-10-29

KiCad E.D.A. kicad 5.1.6+dfsg1-1

Rev: 2.0R-2C

Id: 2/9

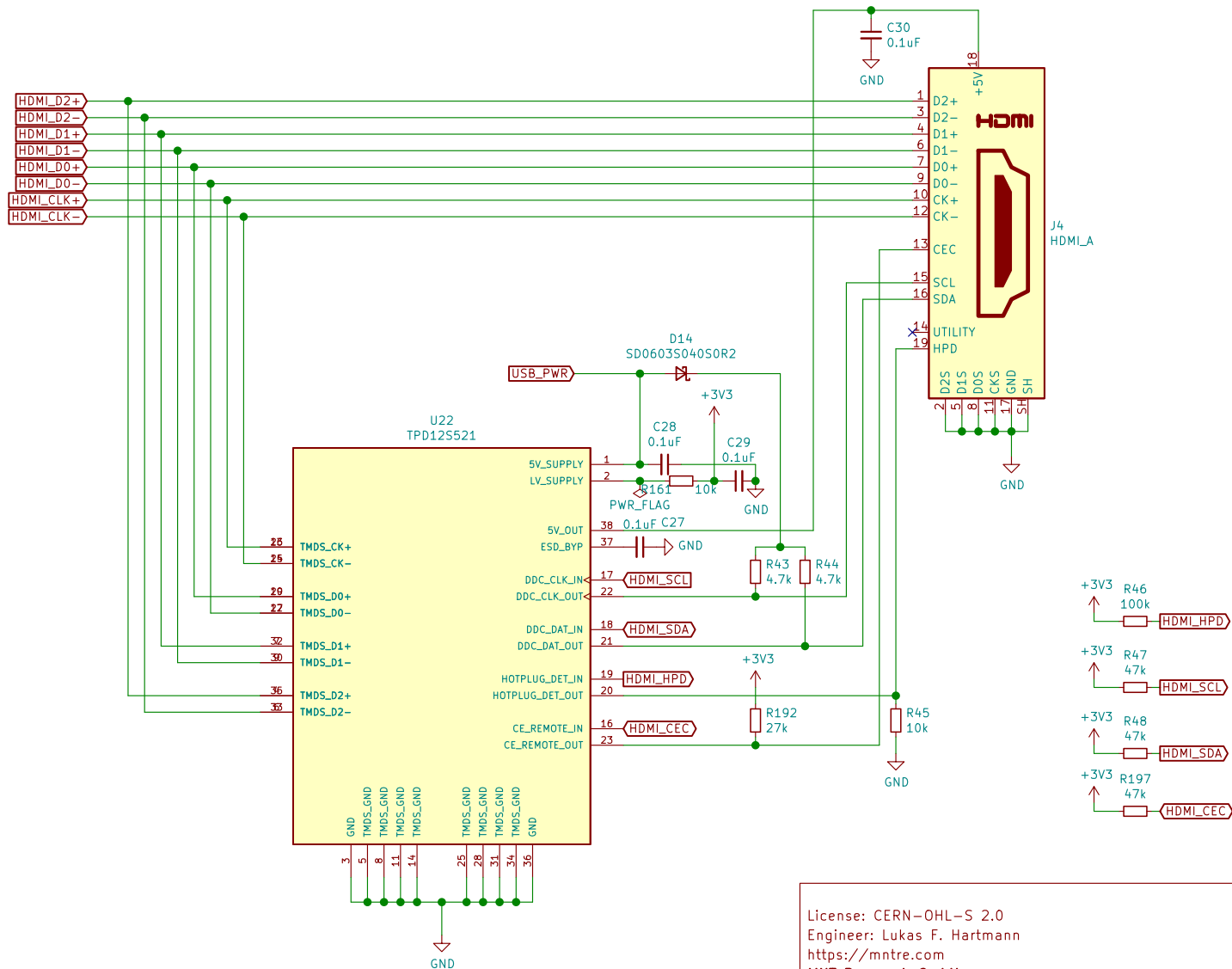

License: CERN-OHL-S 2.0
 Engineer: Lukas F. Hartmann
<https://mntre.com>

MNT Research GmbH

Sheet: /Reform 2 HDMI/
 File: reform2-hdmi.sch

Title: MNT Reform 2 External Display

Size: A4 Date: 2020-10-29

KiCad E.D.A. kicad 5.1.6+dfsg1-1

Rev: 2.0R-2C

Id: 3/9

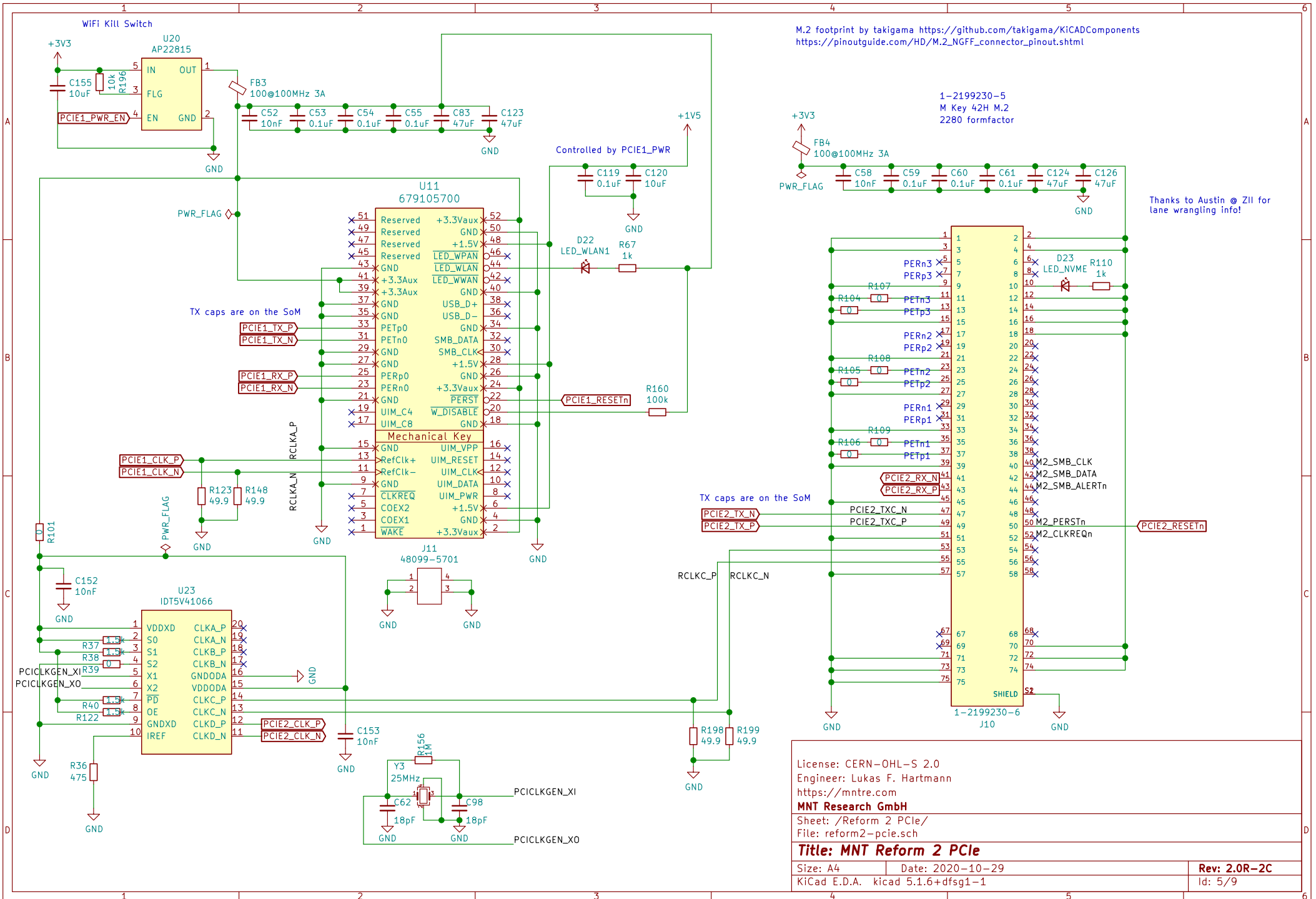

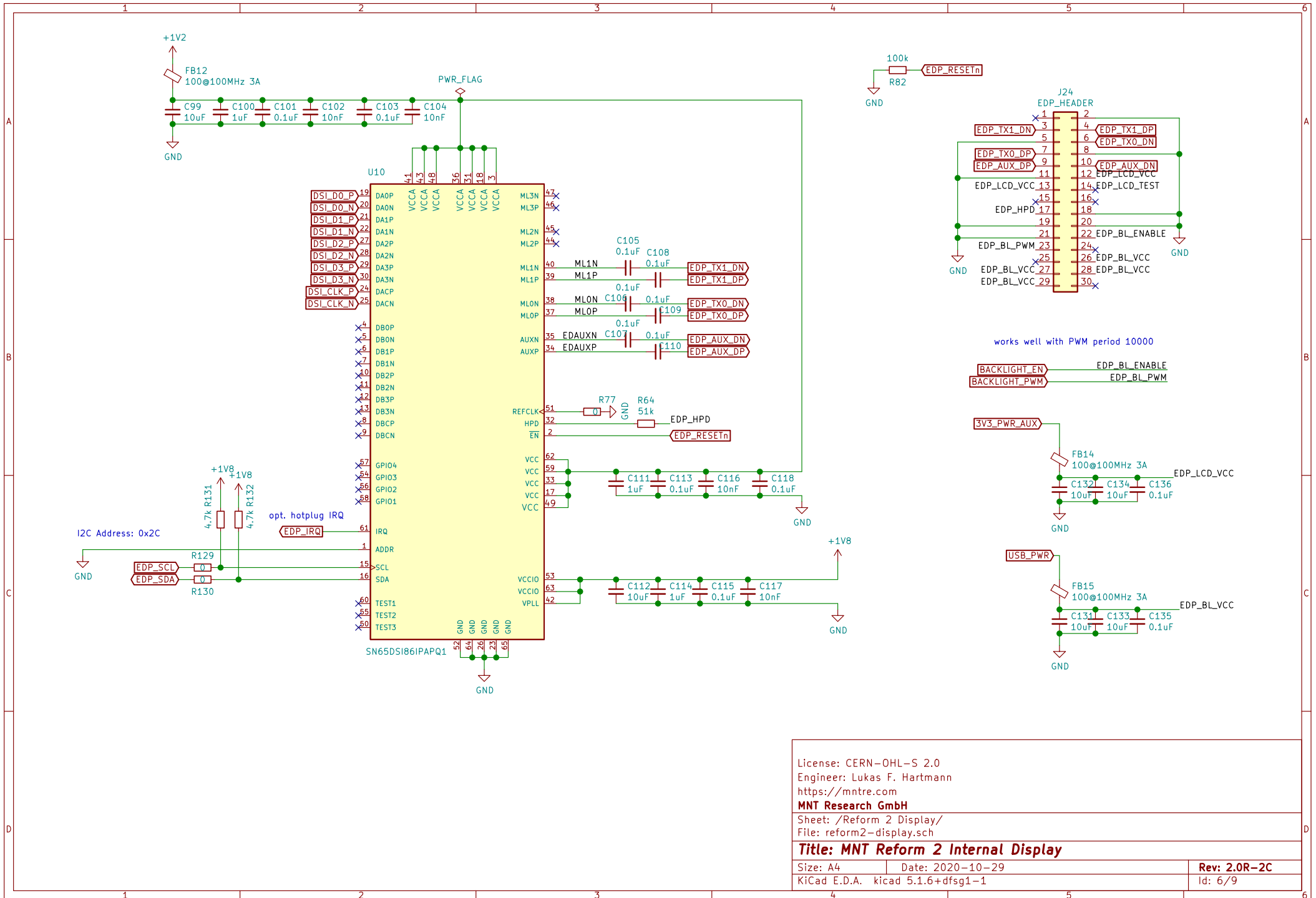

License: CERN-OHL-S 2.0
 Engineer: Lukas F. Hartmann
<https://mntre.com>

MNT Research GmbH

Sheet: /Reform 2 Display/
 File: reform2-display.sch

Title: MNT Reform 2 Internal Display

Size: A4 Date: 2020-10-29

KiCad E.D.A. kicad 5.1.6+dfsg1-1

Rev: 2.0R-2C

Id: 6/9

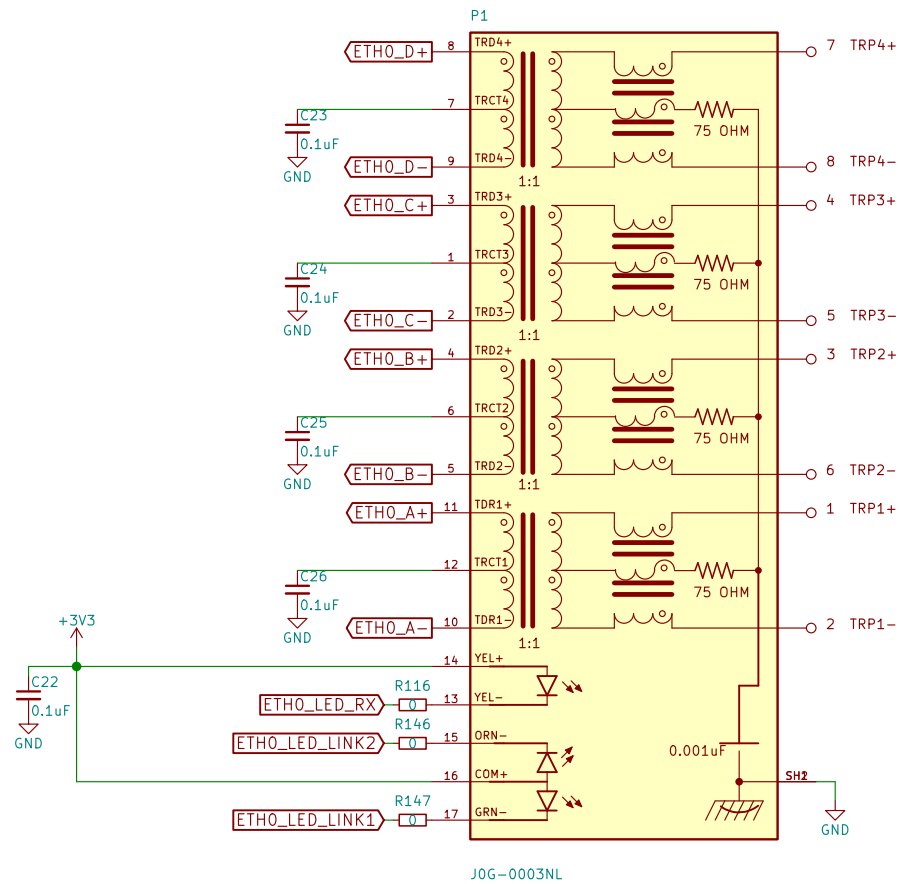

J0G-0003NL
 Equiv: TE 1-2301994-1

License: CERN-OHL-S 2.0
 Engineer: Lukas F. Hartmann
<https://mntre.com>

MNT Research GmbH

Sheet: /Reform 2 Ethernet/
 File: reform2-eth.sch

Title: MNT Reform 2 Ethernet

Size: A4 Date: 2020-10-29
 KiCad E.D.A. kicad 5.1.6+dfsg1-1

Rev: 2.0R-2C
 Id: 7/9

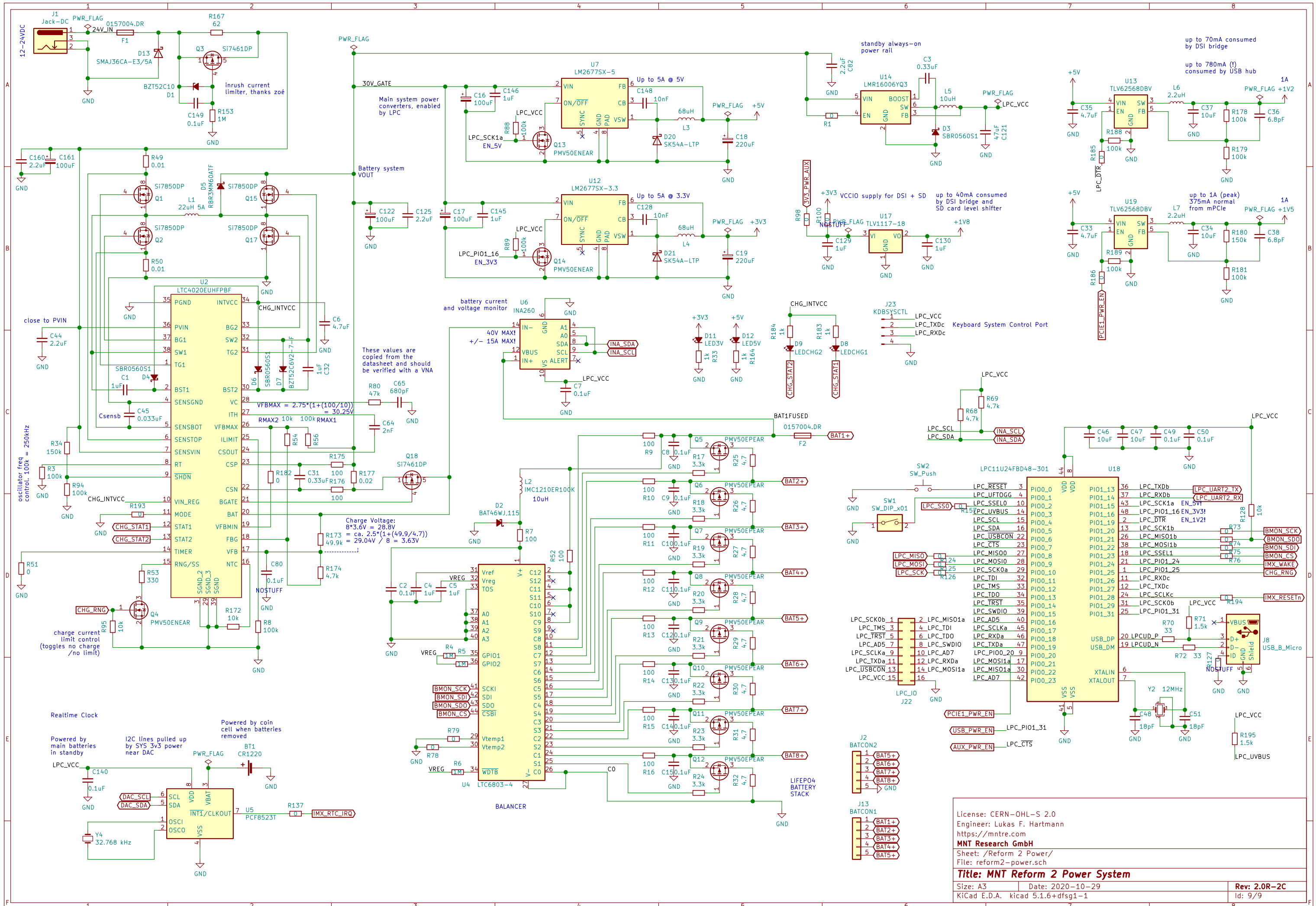

License: CERN-OHL-S 2.0
 Engineer: Lukas F. Hartmann
<https://mntre.com>
MNT Research GmbH
 Sheet: /Reform 2 Power/
 File: reform2-power.sch
Title: MNT Reform 2 Power System
 Size: A3 | Date: 2020-10-29 | Rev: 2.0R-2C
 KiCad E.D.A. kicad 5.1.6+dfsg1-1 | Id: 9/9